

# JSM meshes for the HLPW-3 generated with ANSA v17.1.0

February 2017

Vangelis Skaperdas

BETA CAE Systems

[ansa@beta-cae.com](mailto:ansa@beta-cae.com)

<http://www.beta-cae.com>

# Summary of created meshes for the JSM model

Four meshes were created.

	Medium Case 01 (w/o nacelle)	Medium Case 02 (with nacelle)	Fine Case 01 (w/o nacelle)	Fine Case 02 (with nacelle)
Surface mesh size (millions)	1.7	1.8	2.1	2.2
Volume mesh size (millions)	109	120	165	190
Trailing edge rows of elements	8	8	10	10
Number of Layers	Wing:49 Fuselage:57	Wing:49 Fuselage:57	Wing:72 Fuselage:84	Wing:72 Fuselage:84
Layers growth	1.16	1.16	1.10	1.10
Layers first height (mm)	0.0015	0.0015	0.0015	0.0015

Meshes are in millimetres.

Output formats are OpenFOAM and CGNS.

CGNS meshes have farfield boundary of hemispherical domain set as wall type and should be changed accordingly for each solver.

# Three identified problem areas in the original geometry

## Locations of no valid normal vector for layers at contacts of slat with main wing

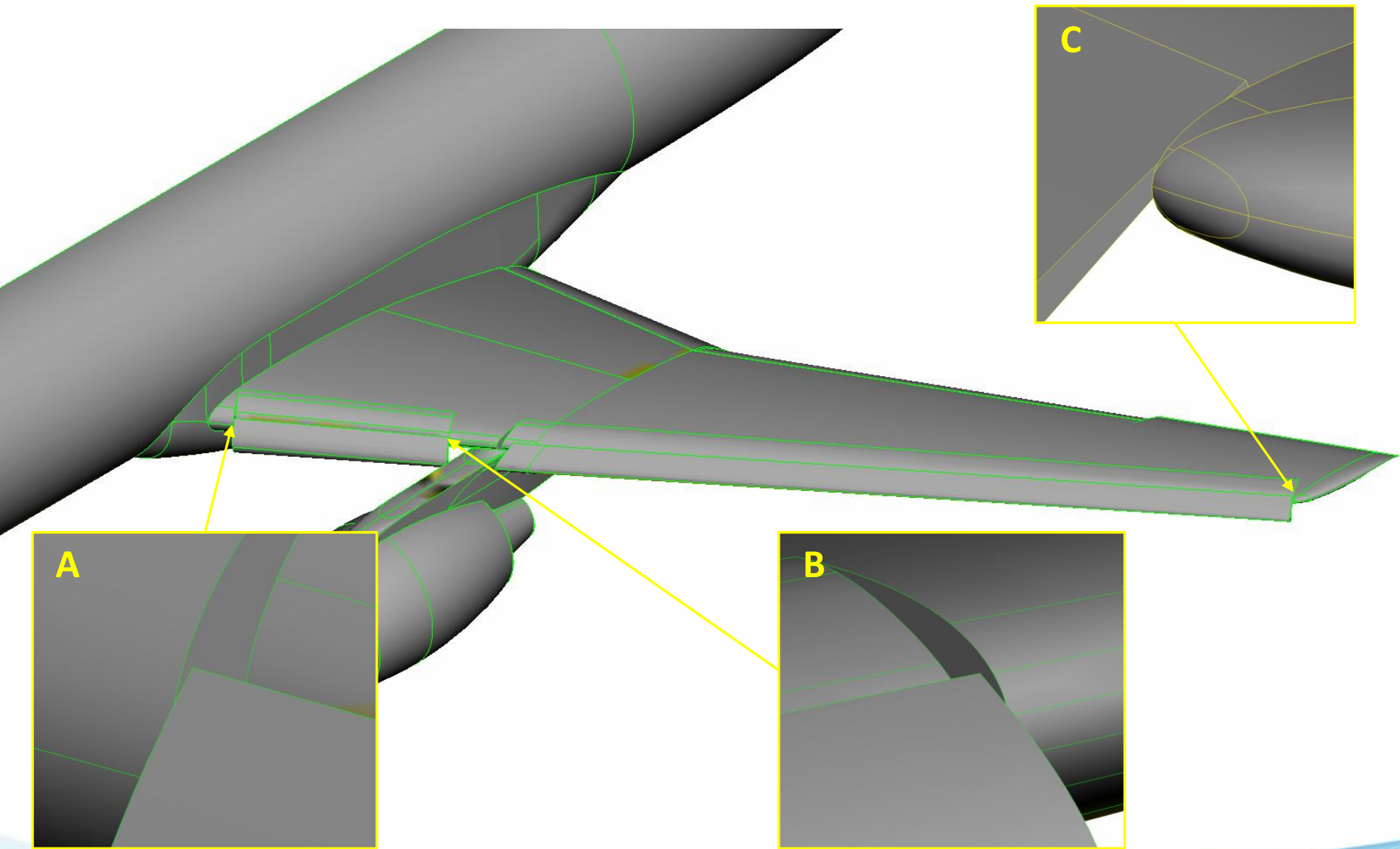

# Small surfaces (in yellow) added in ANSA to alleviate the problem

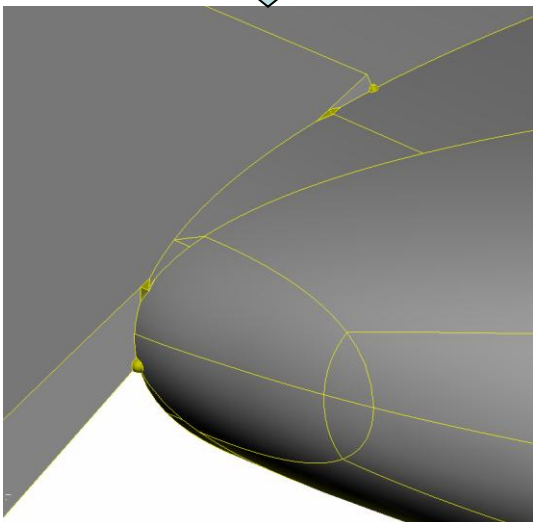
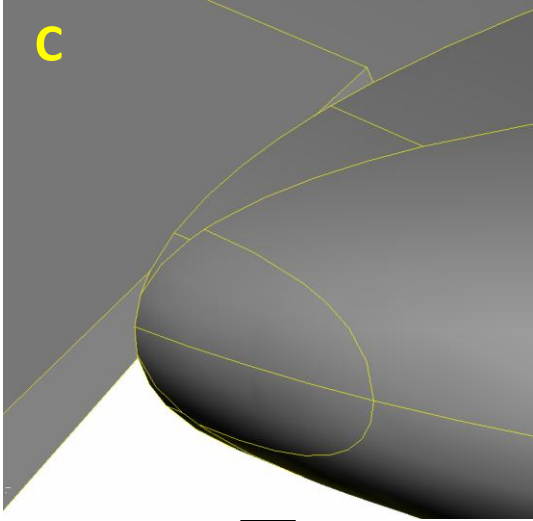
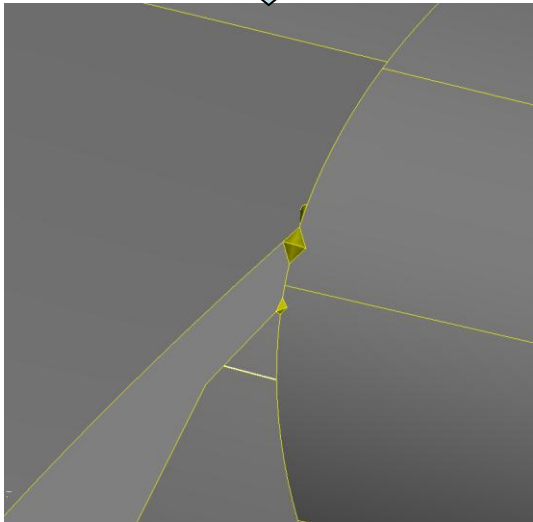
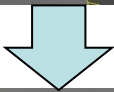
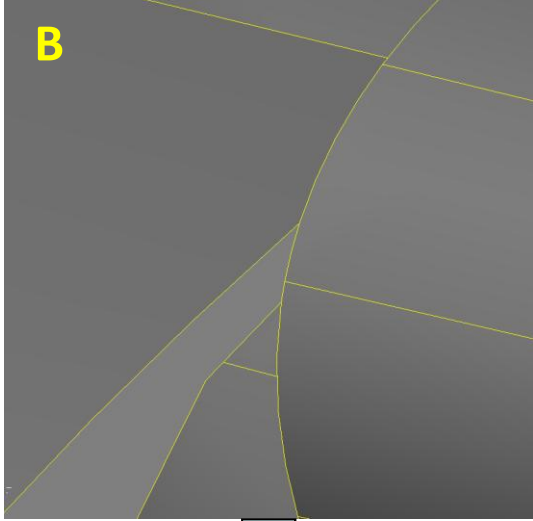
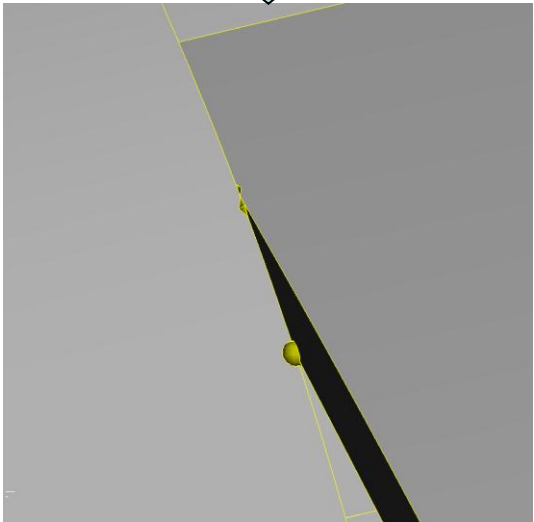
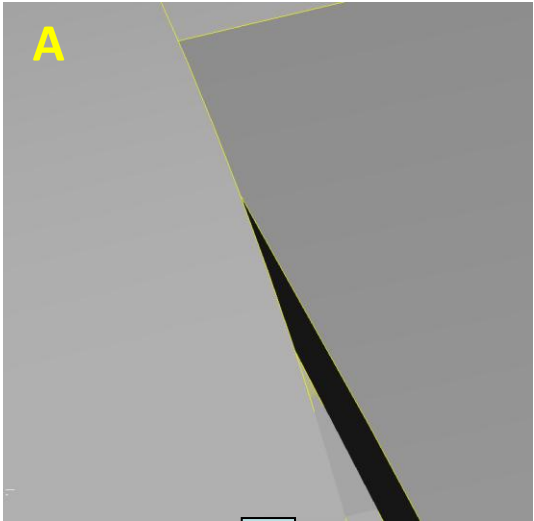

# Model separated in 15 areas

## Size Boxes define additional surface and volume refinement zones

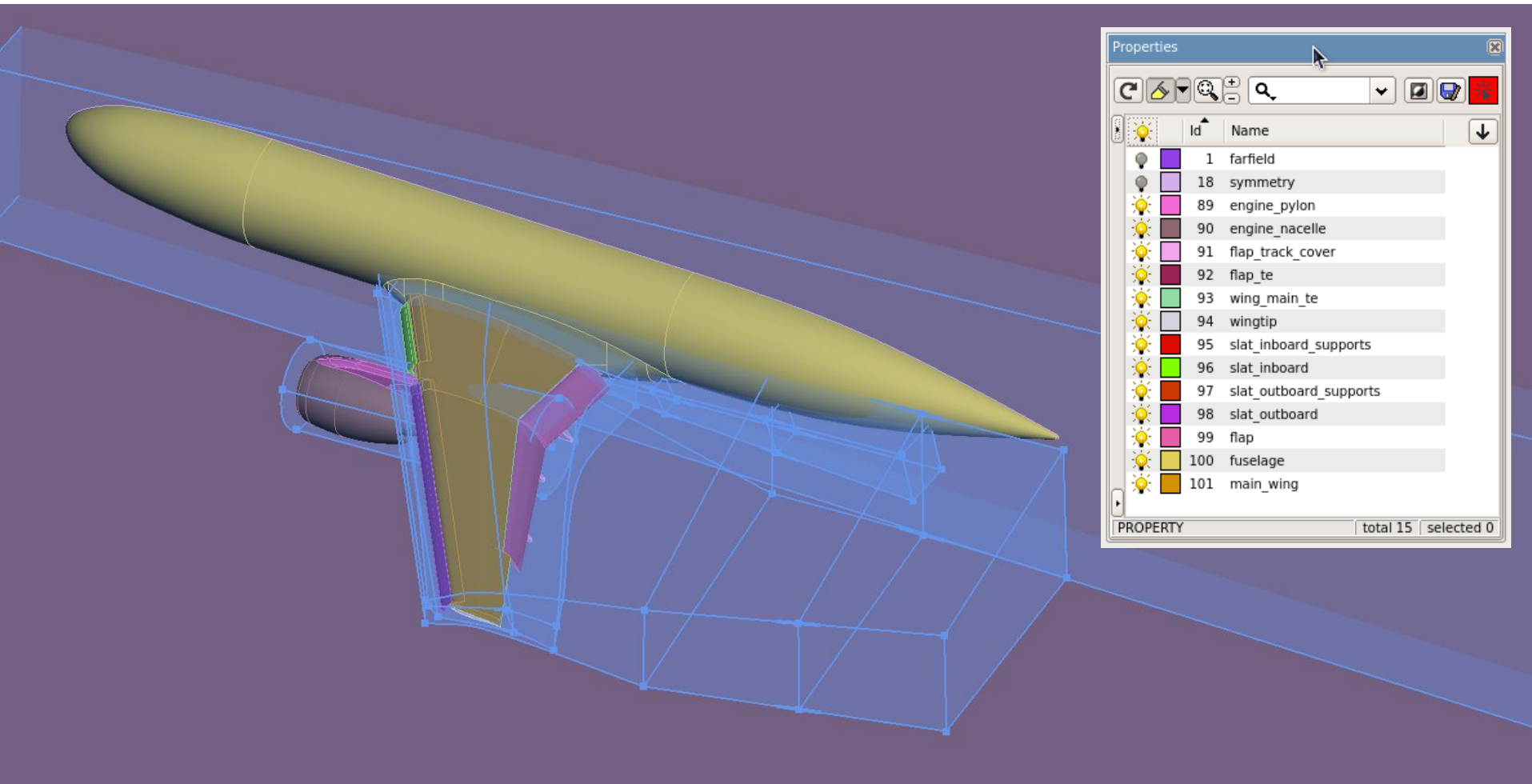

Middle Case 02 model

# Overview of surface mesh (coarse) – 1.8 million elements

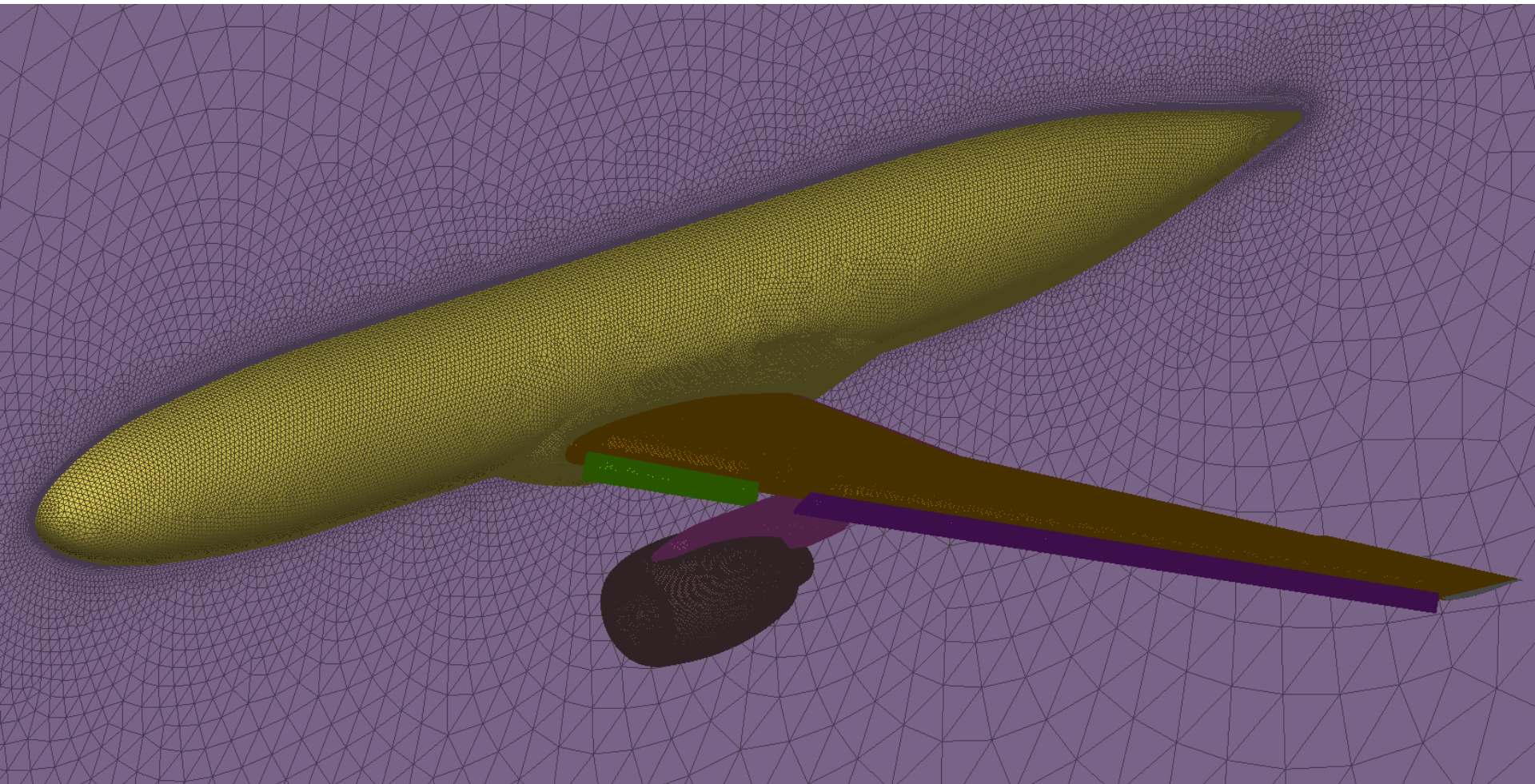

Middle Case 02 model

# Size Boxes used for additional refinement of the surface and volume mesh

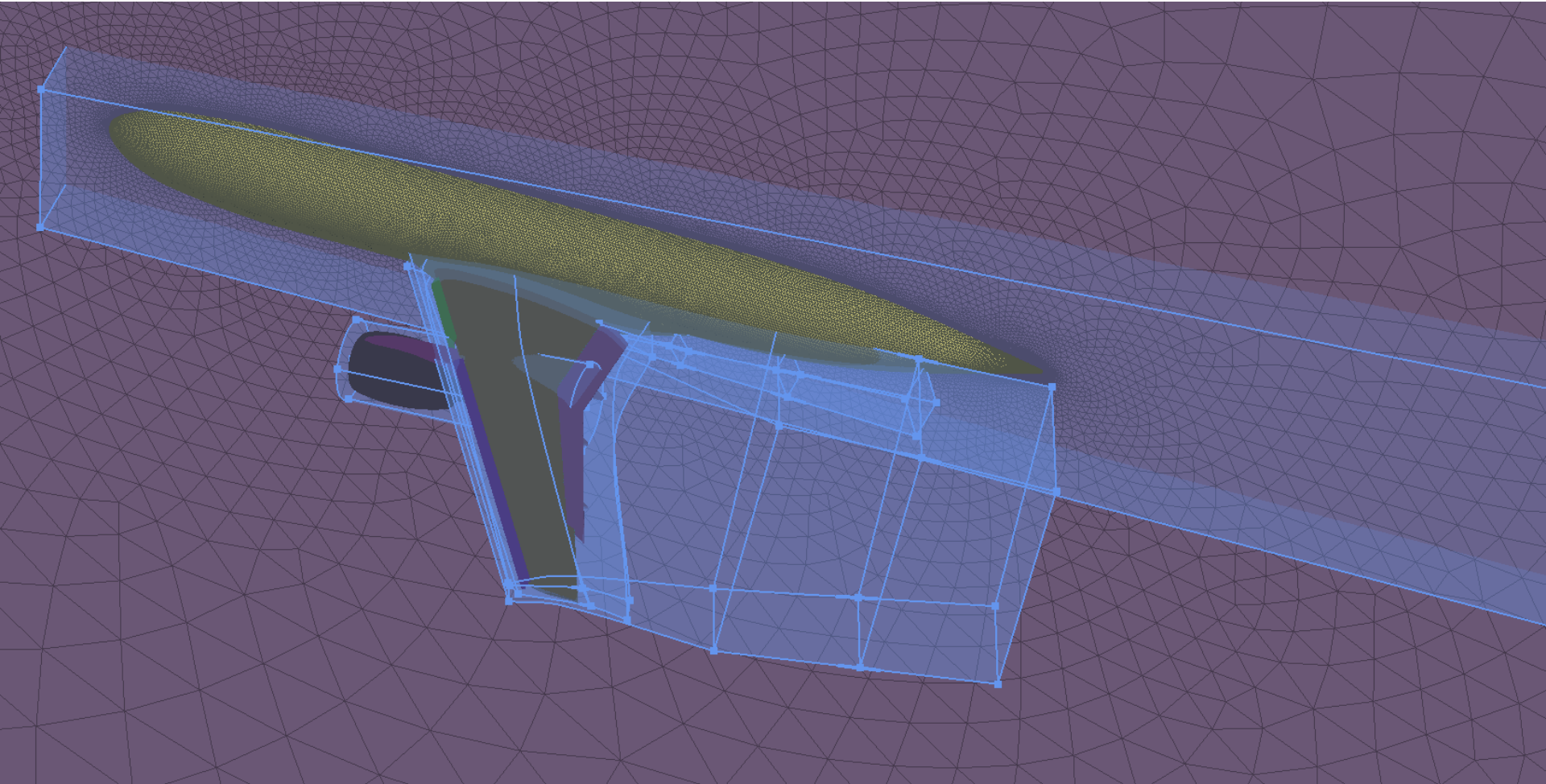

Middle Case 02 model

# Close up of coarse upper wing mesh

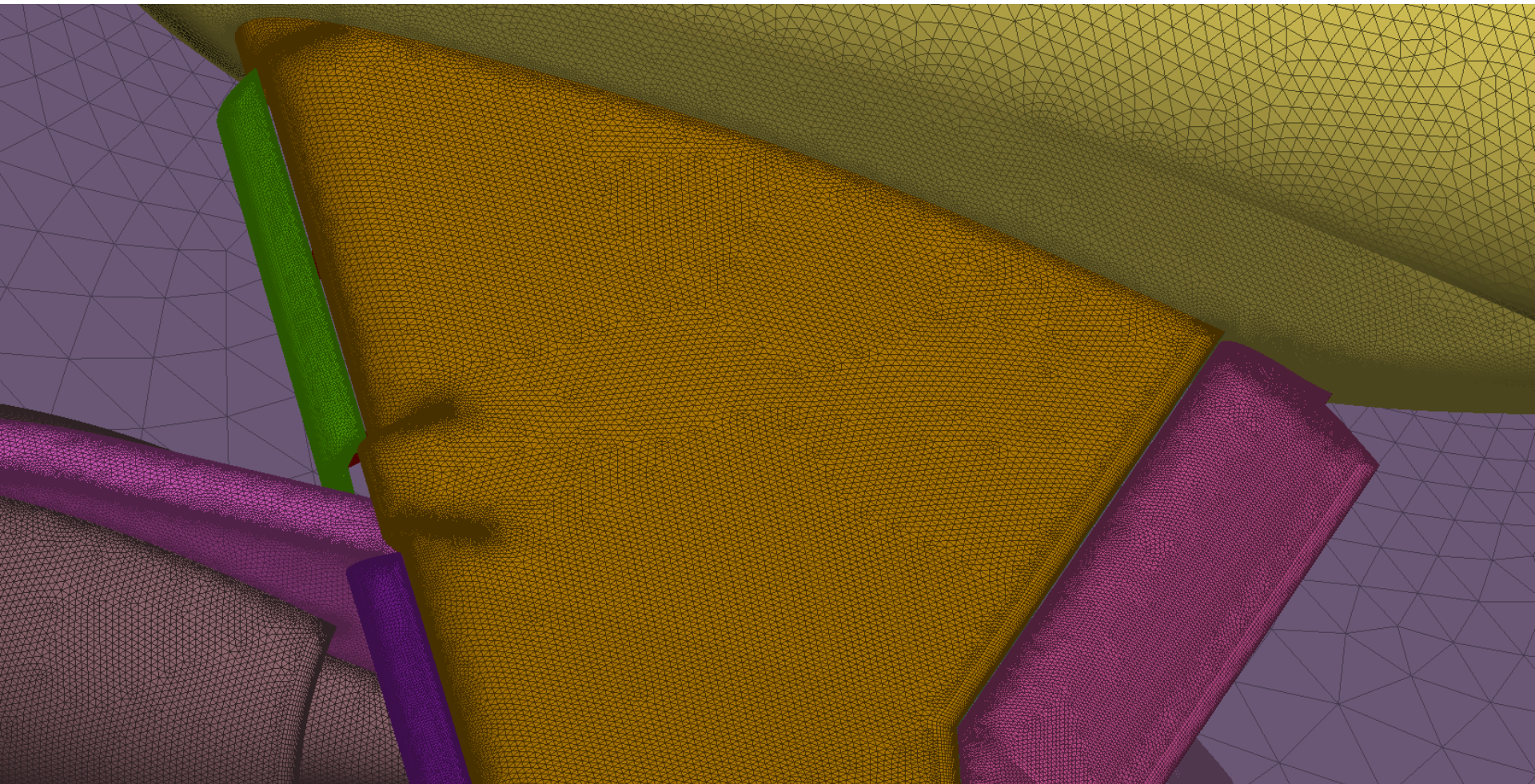

Middle Case 02 model



# Anisotropic quad mesh at the leading and trailing edges of wing, slat and flaps

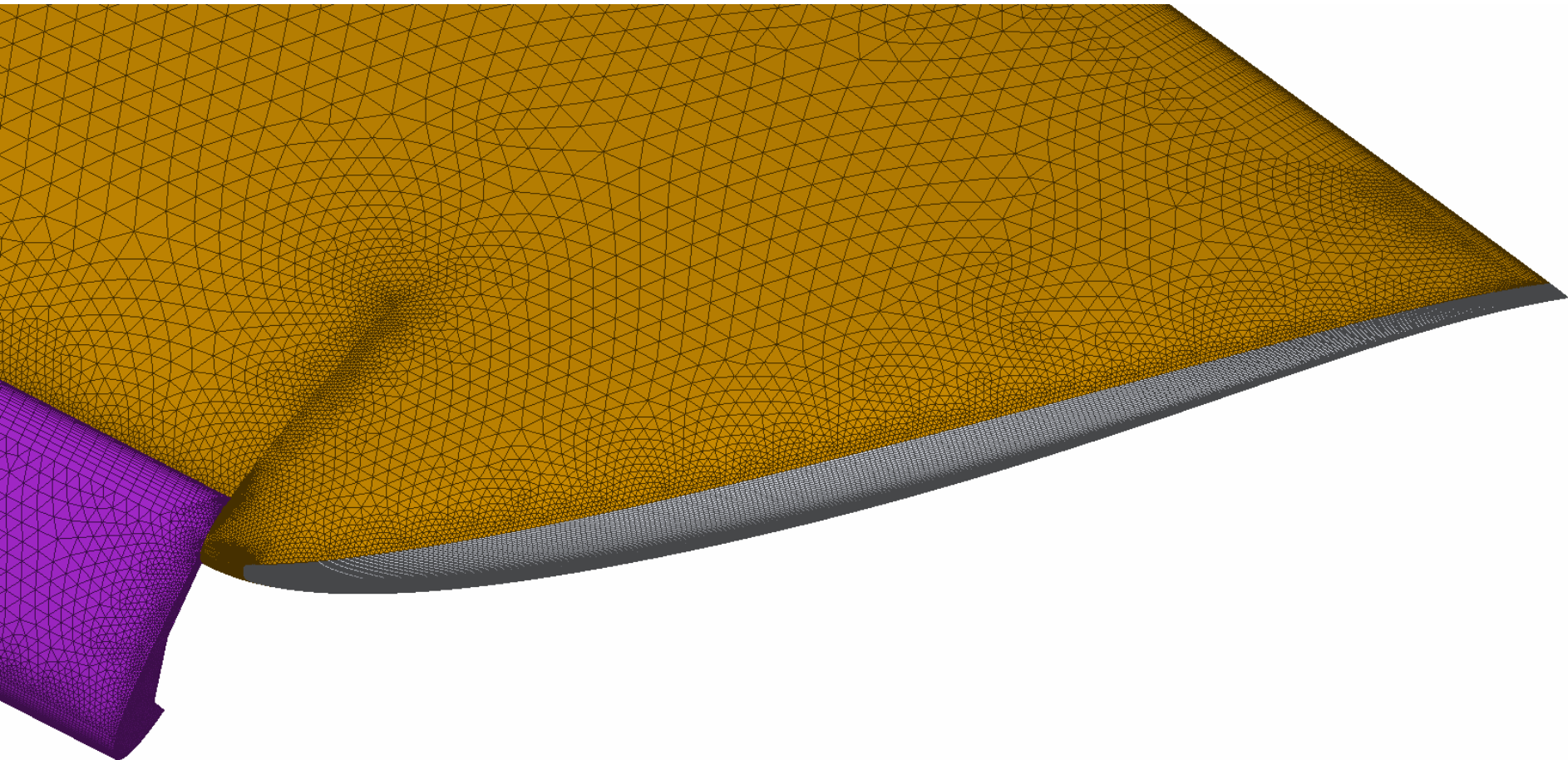

Middle Case 02 model

# Mapped quad mesh across the width of the trailing edge and wingtip

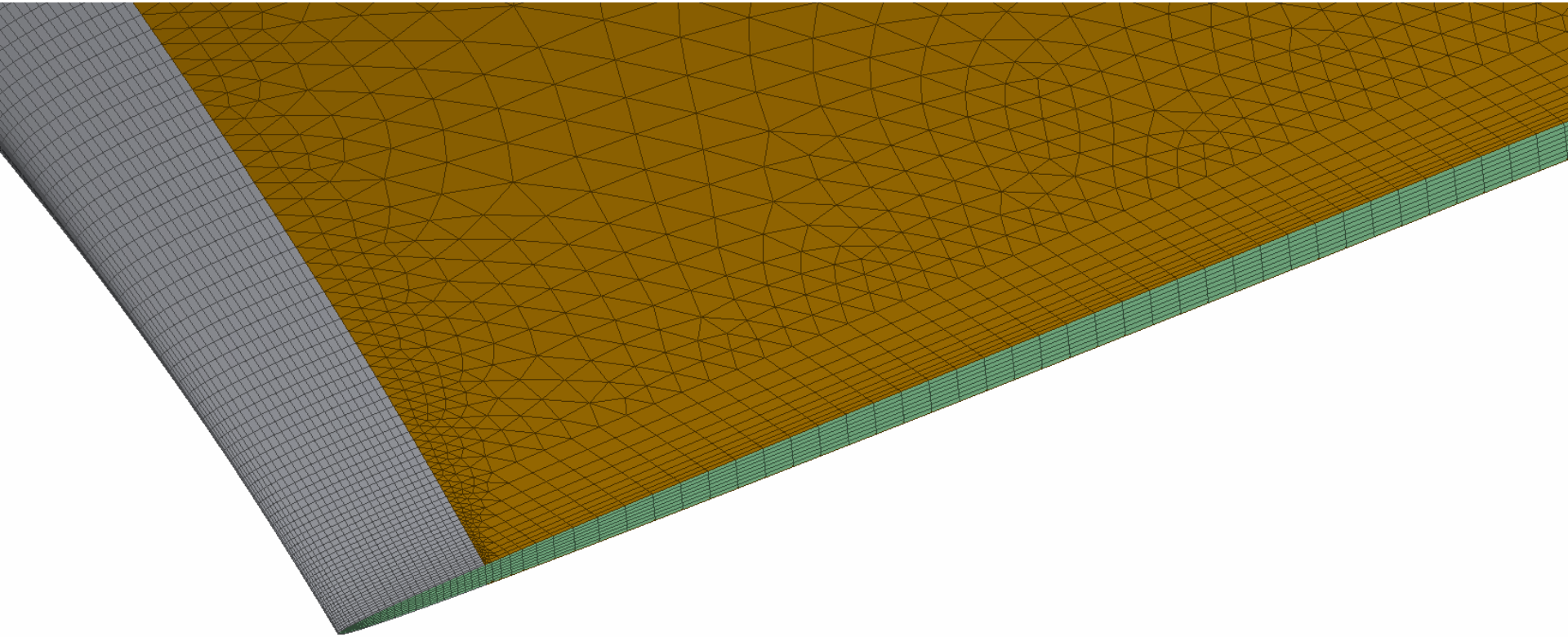

Middle Case 02 model

# Close up of slat connection with the main wing (fixed problem area C earlier)

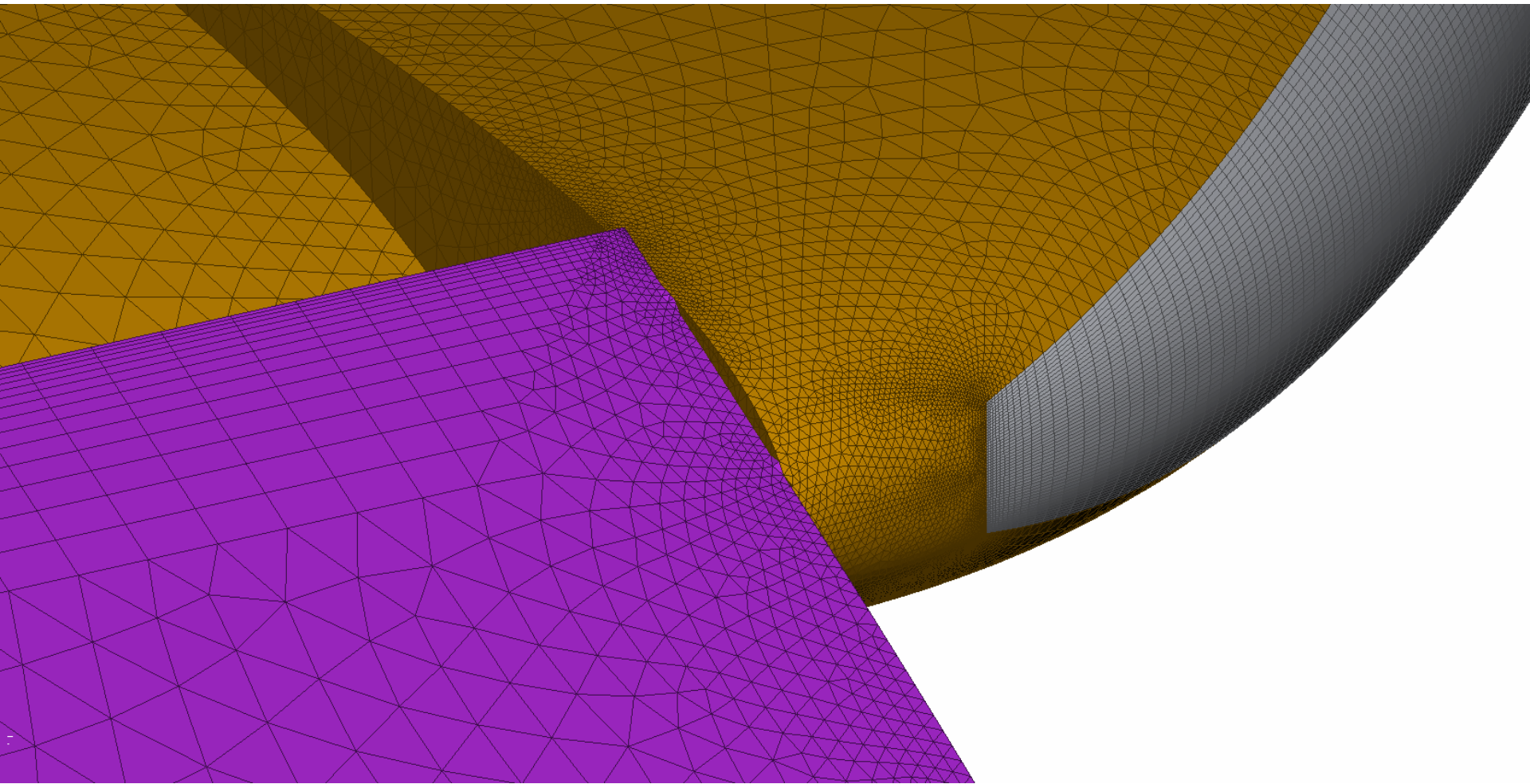

Middle Case 02 model

# Close up engine nacelle of Case02 Fine

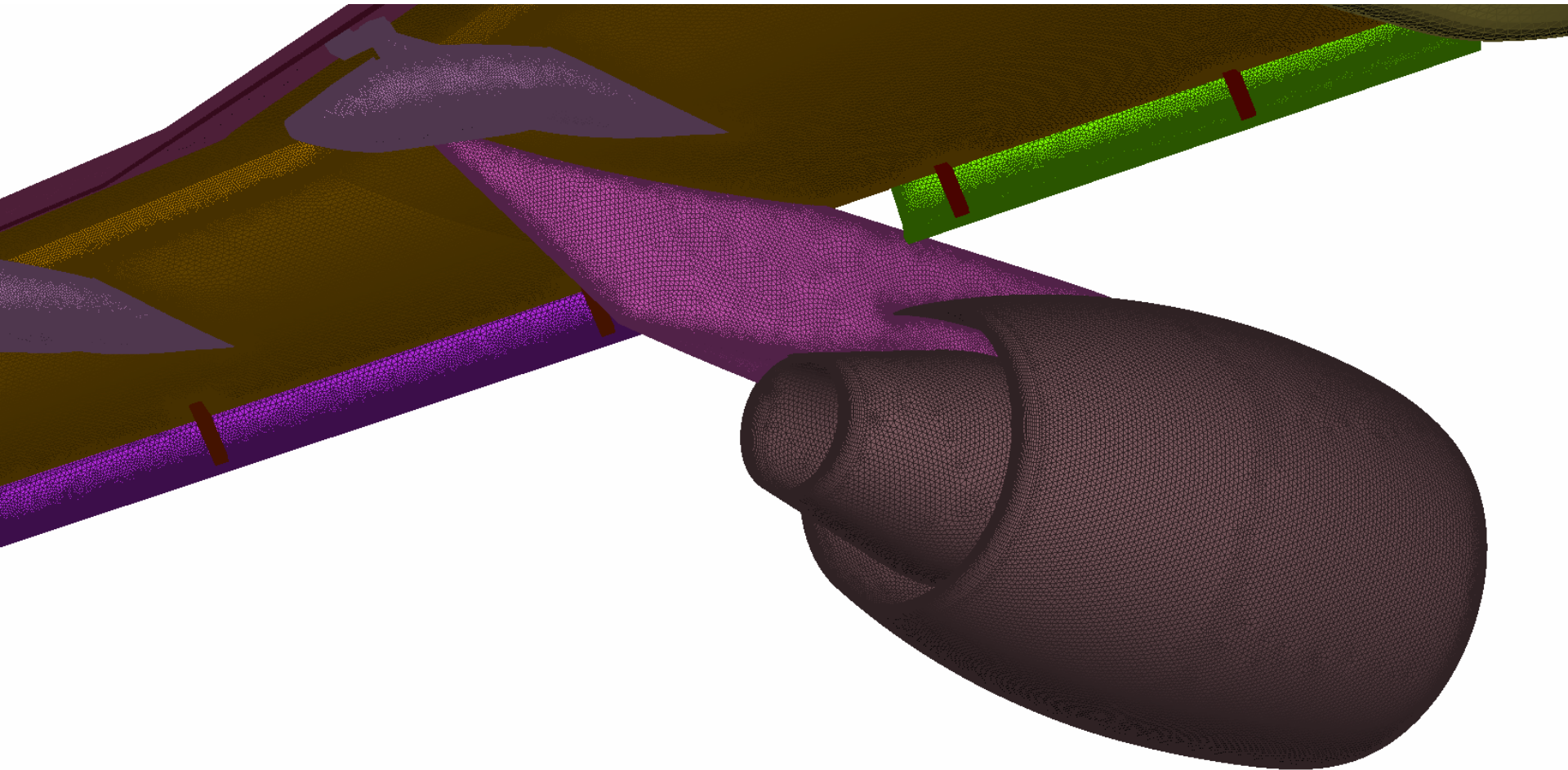

Fine Case 02 model

# Overview of coarse volume mesh – 120 million elements

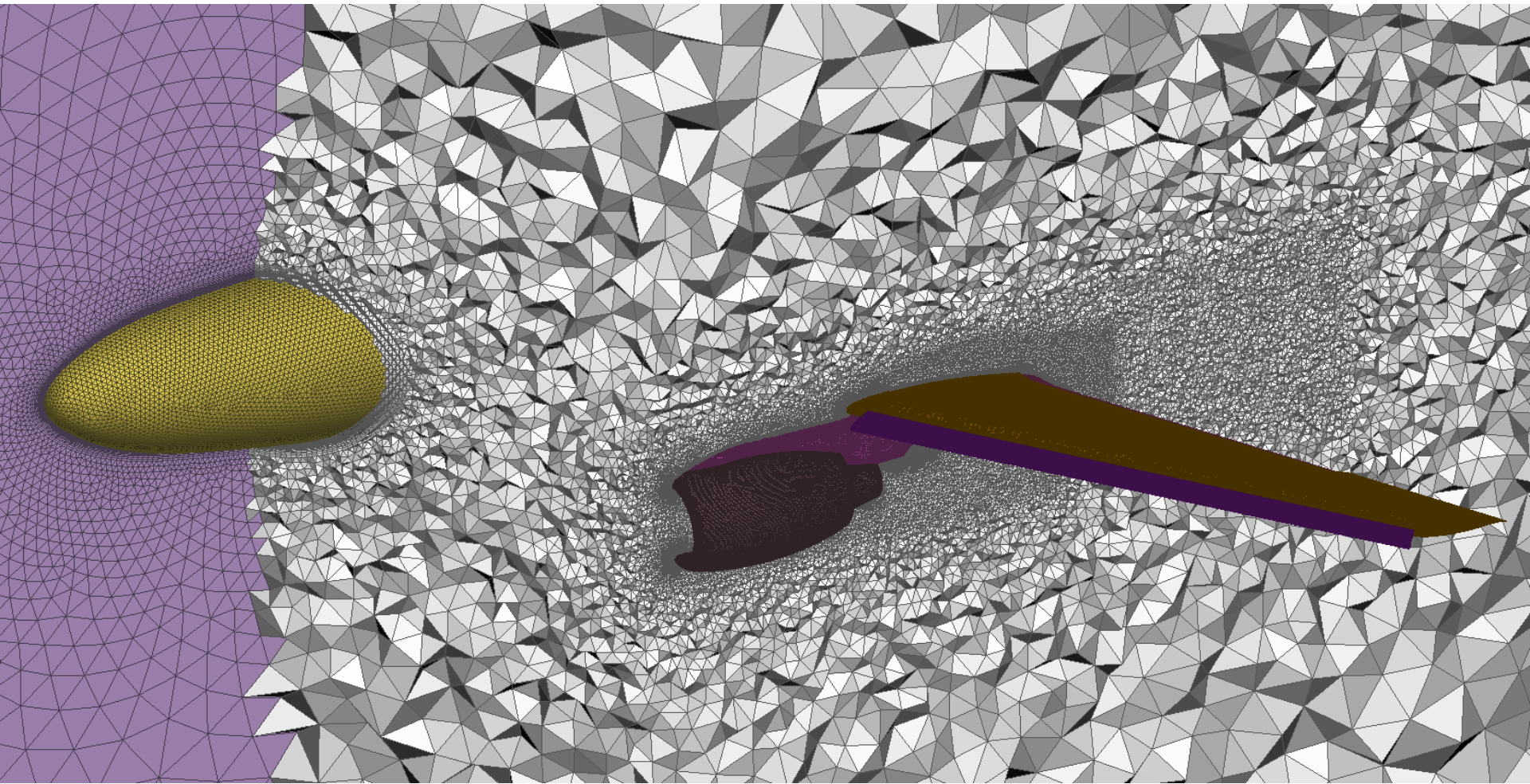

Middle Case 02 model

# Section of mesh near slat main wing proximity

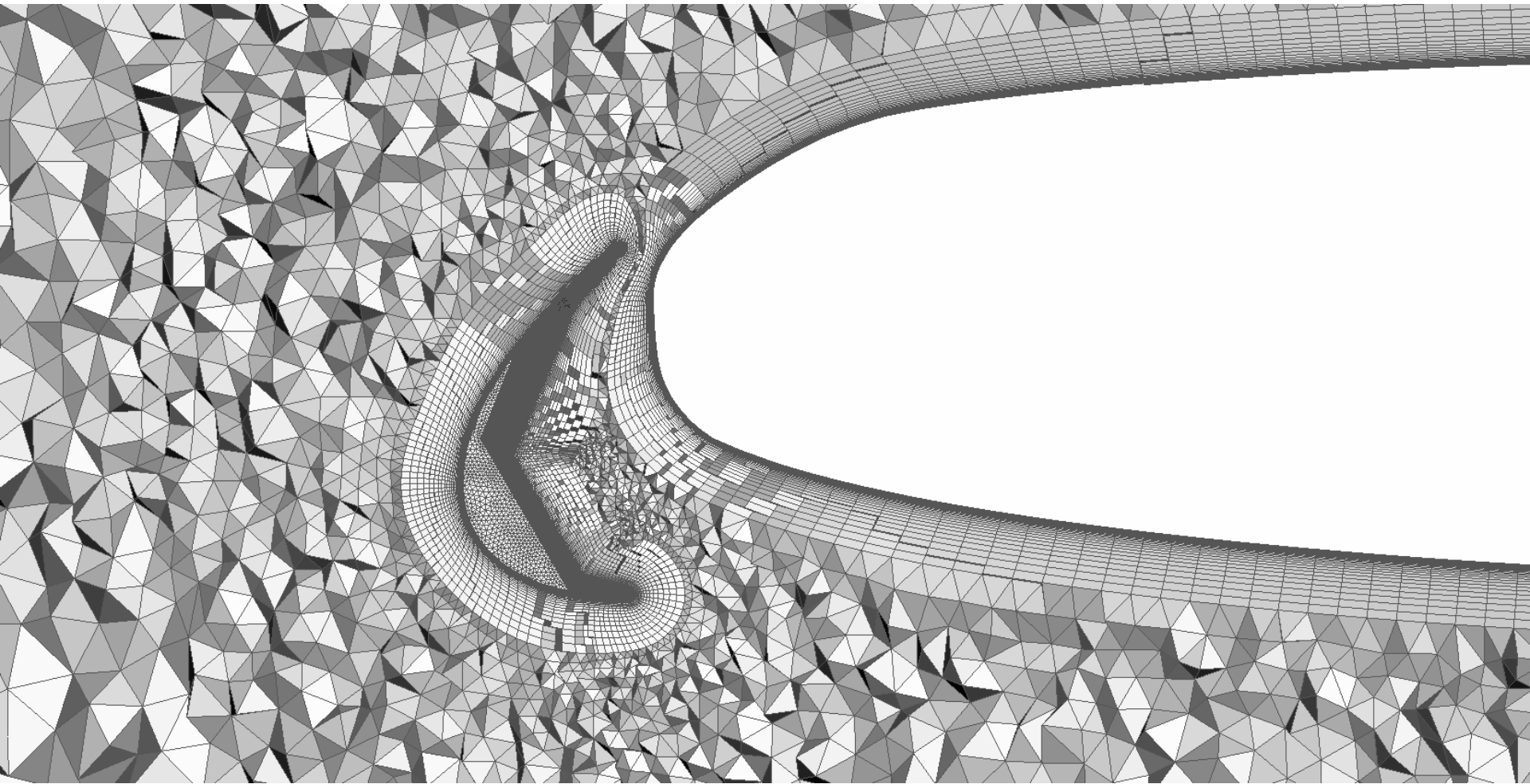

Middle Case 02 model

# Close up near main wing and flap gap

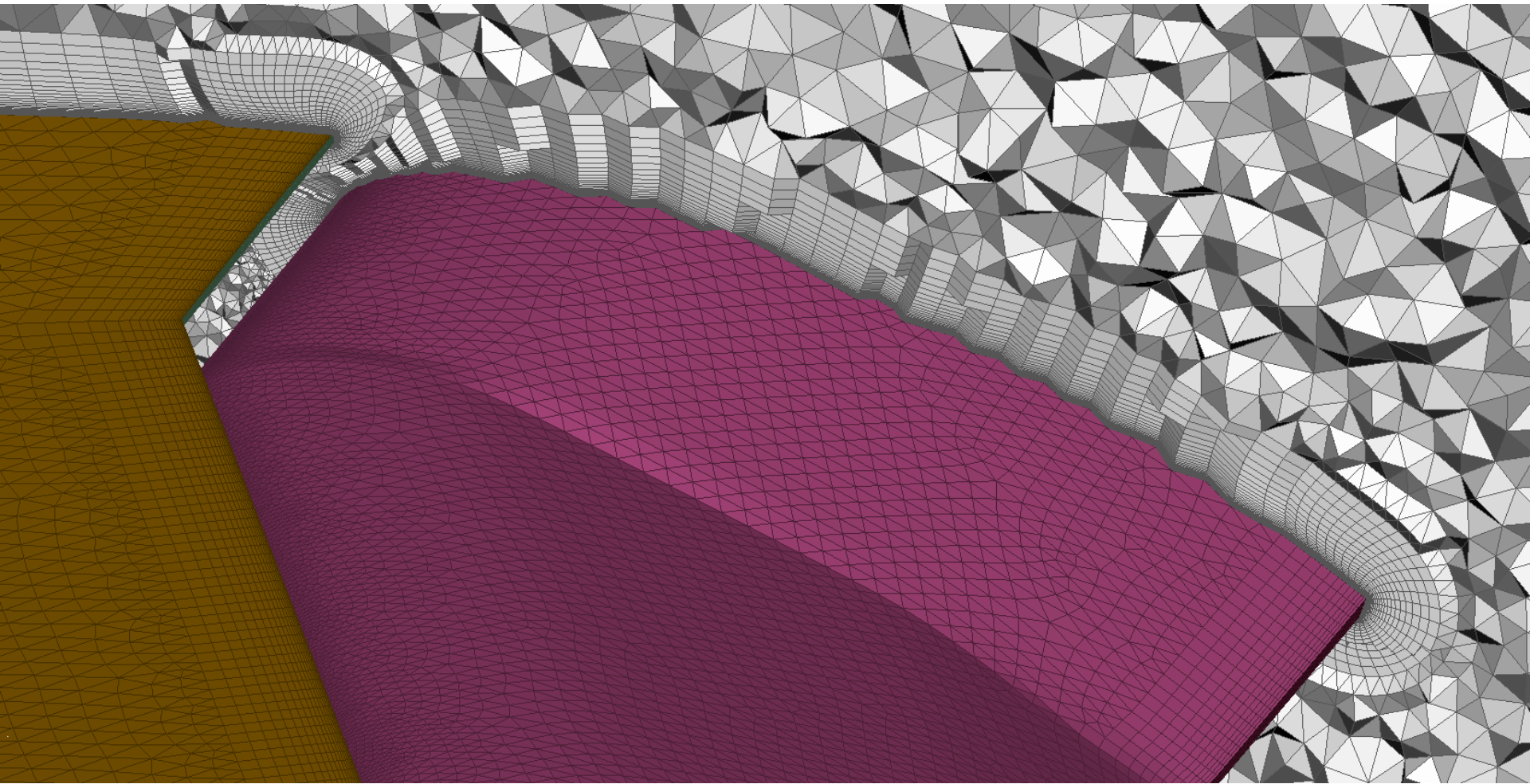

Middle Case 02 model

# Section of the mesh at the main wing and flap gap

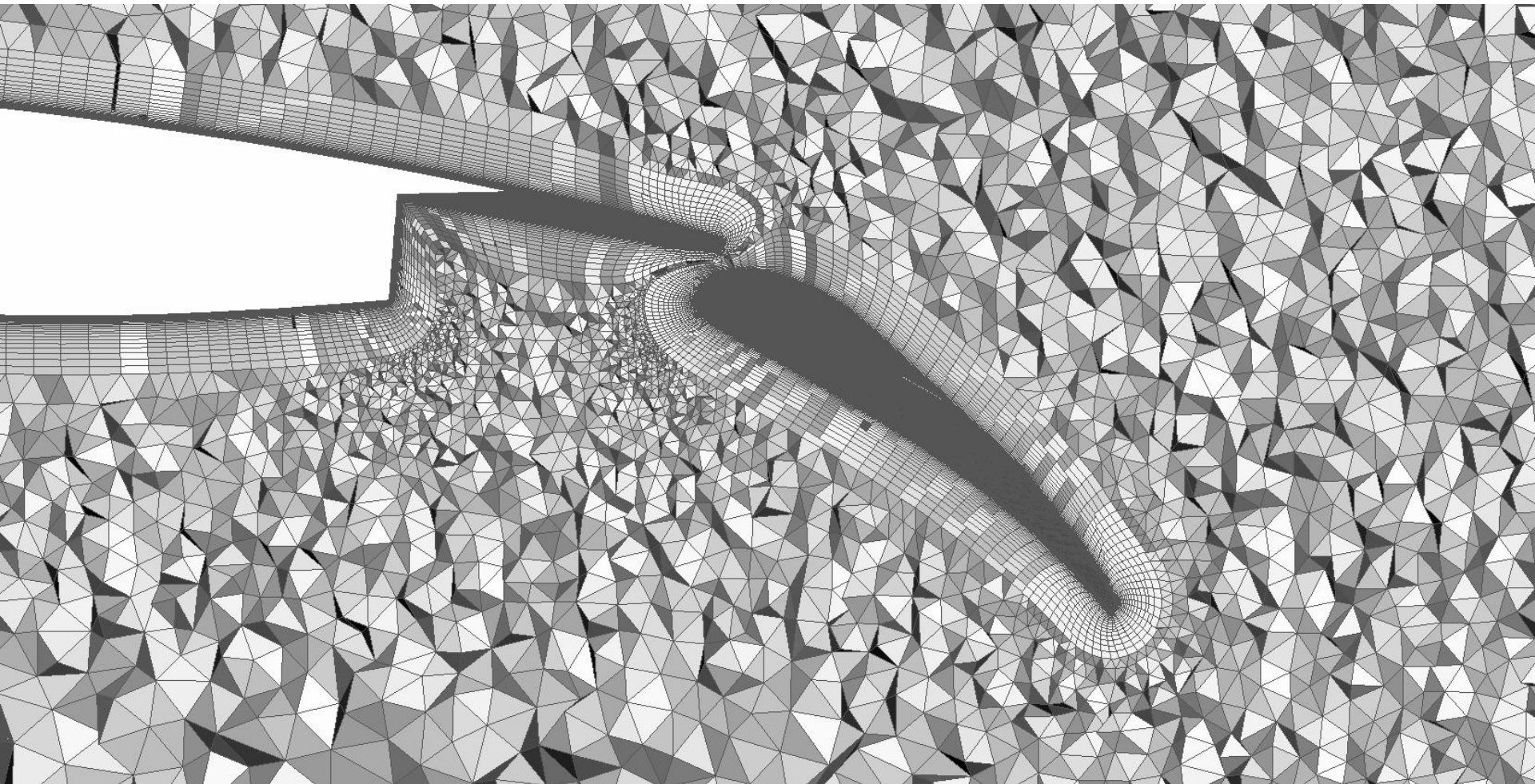

Middle Case 02 model



# Imposed orthogonality of layers near the wall

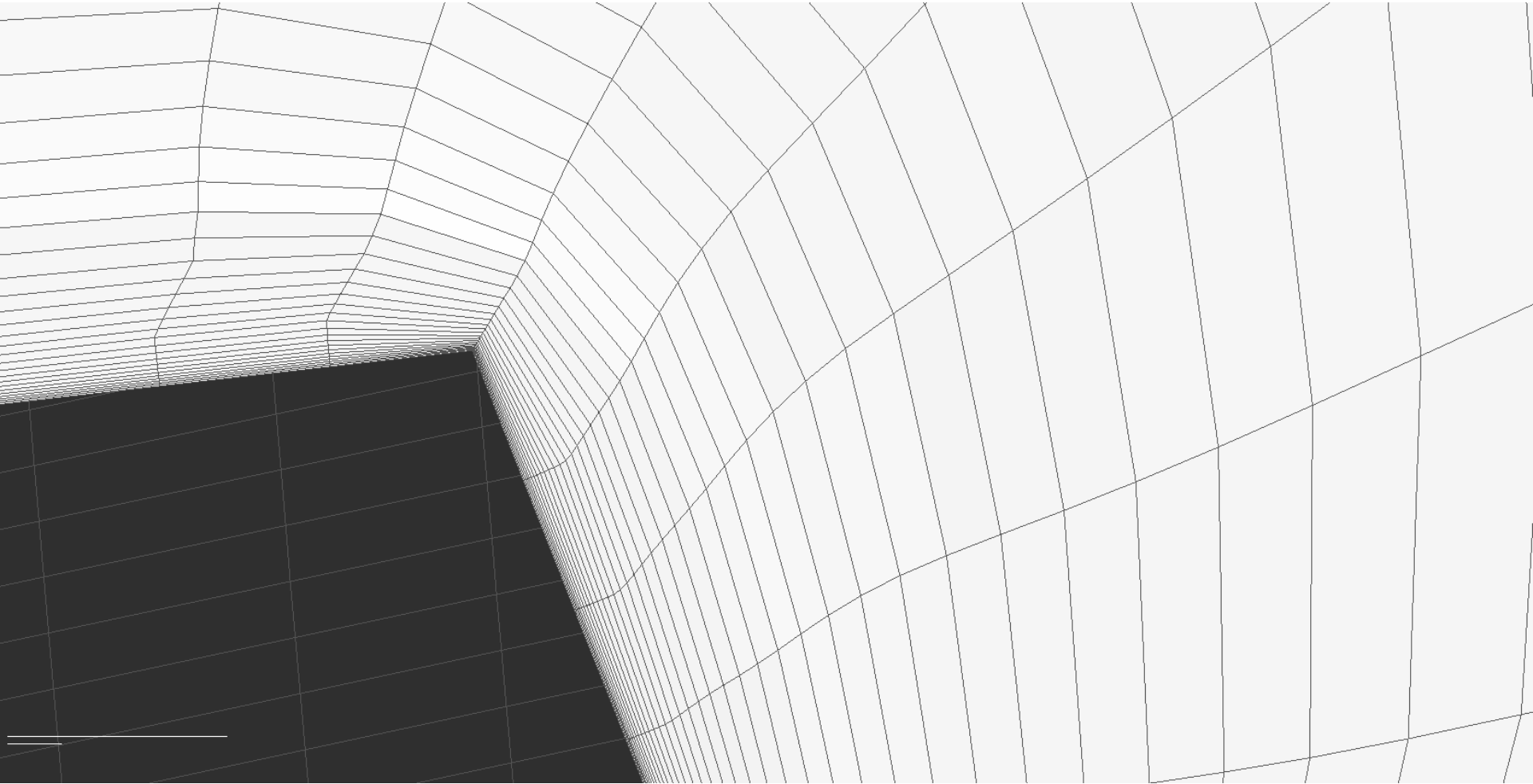

Middle Case 02 model

# Different number of layers from fuselage and wing

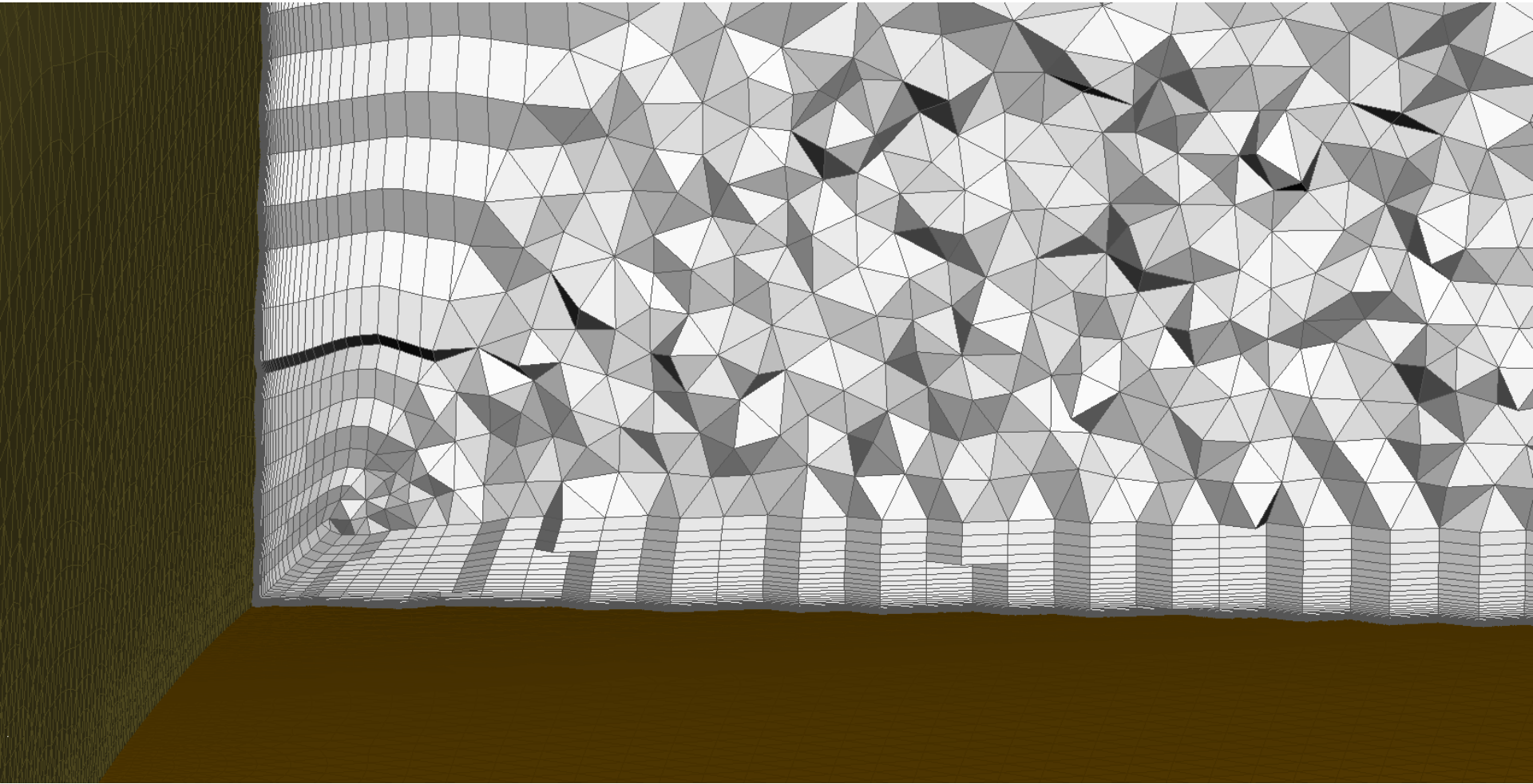

Middle Case 02 model

# Layers across the gap of the main wing and flap

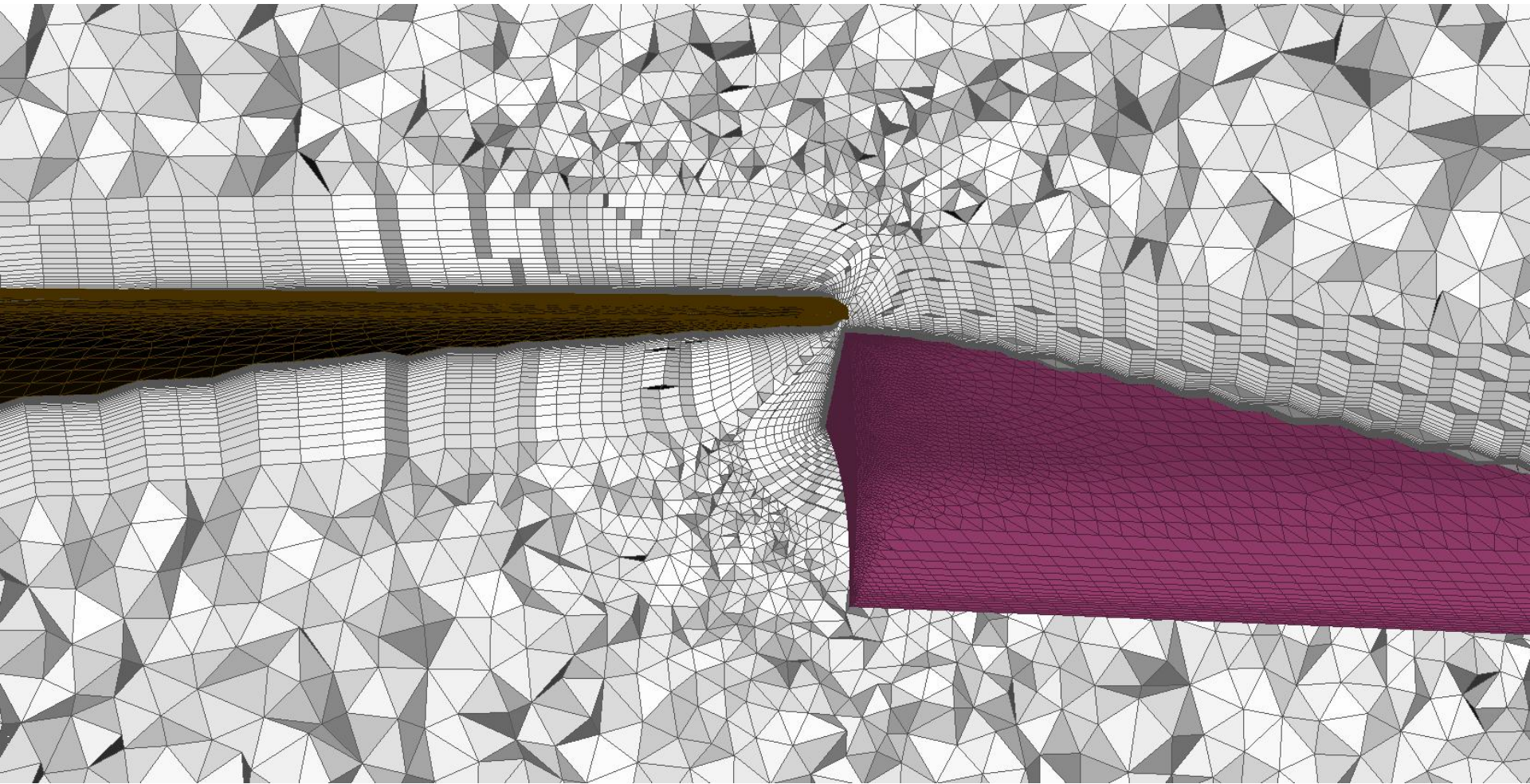

Middle Case 02 model

# Mesh refinement around wing

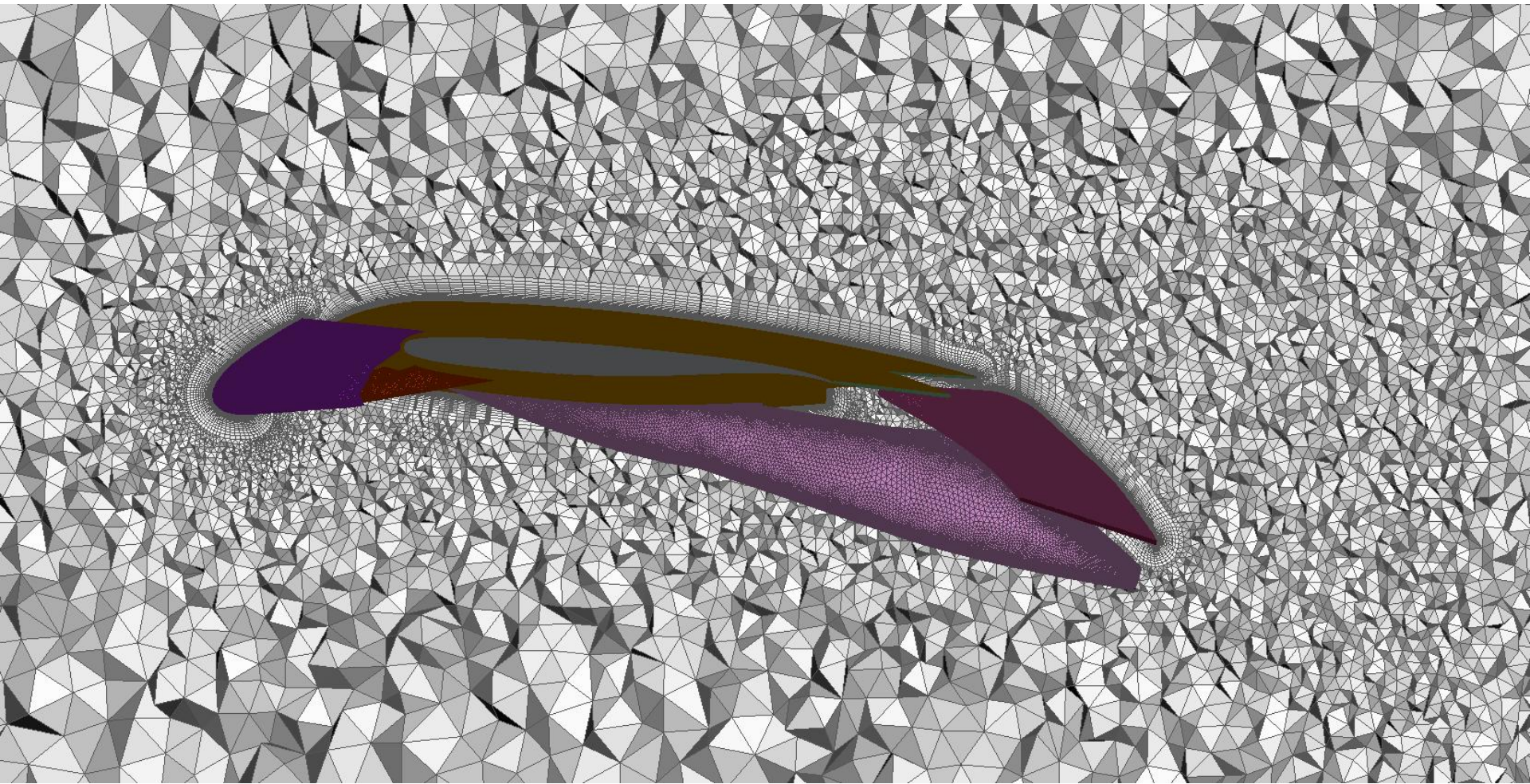

Middle Case 02 model

# Mesh sections

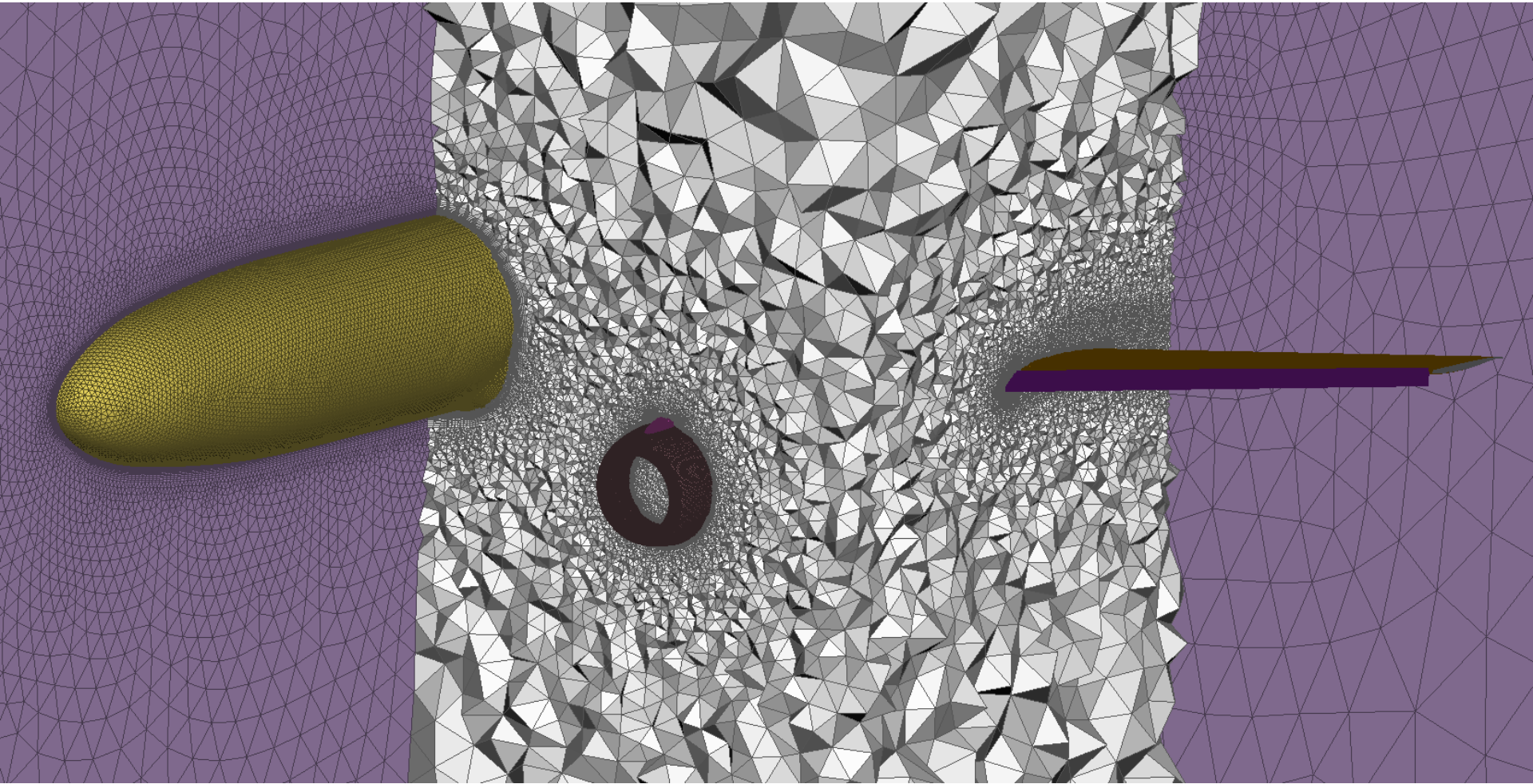

Middle Case 02 model

# Imprinted layers around the symmetry plane

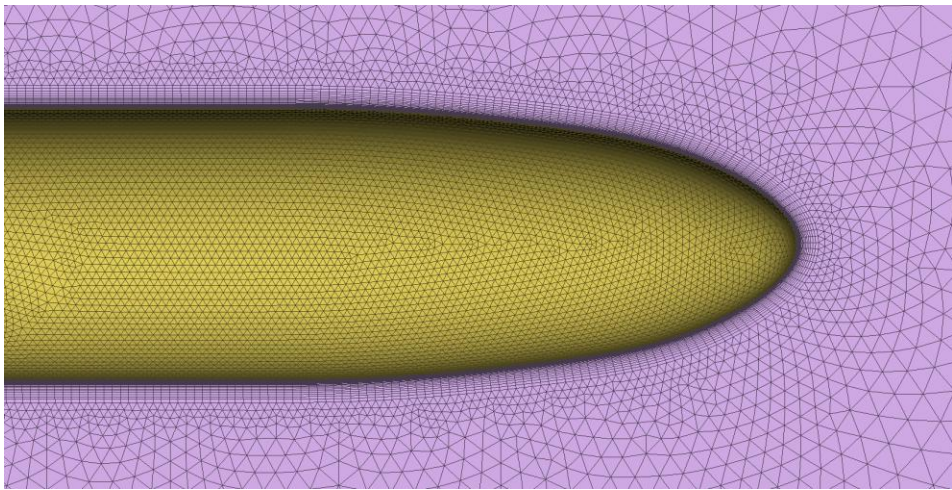
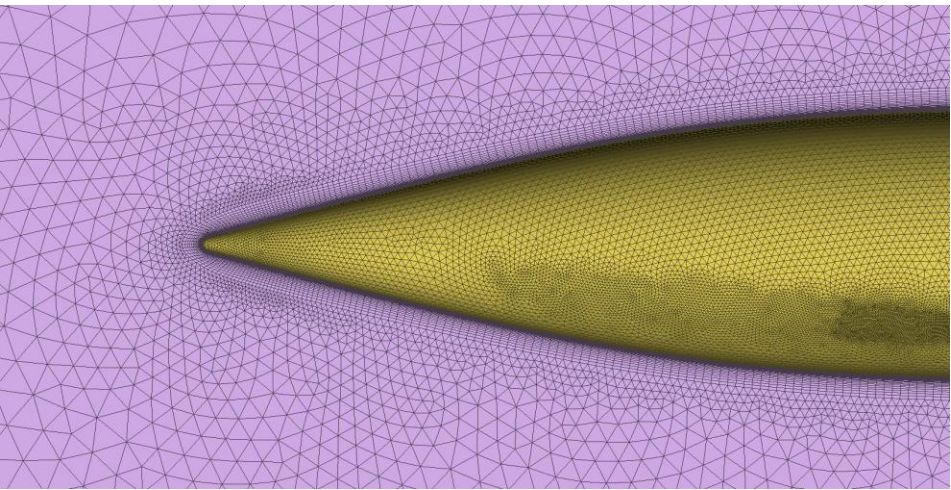
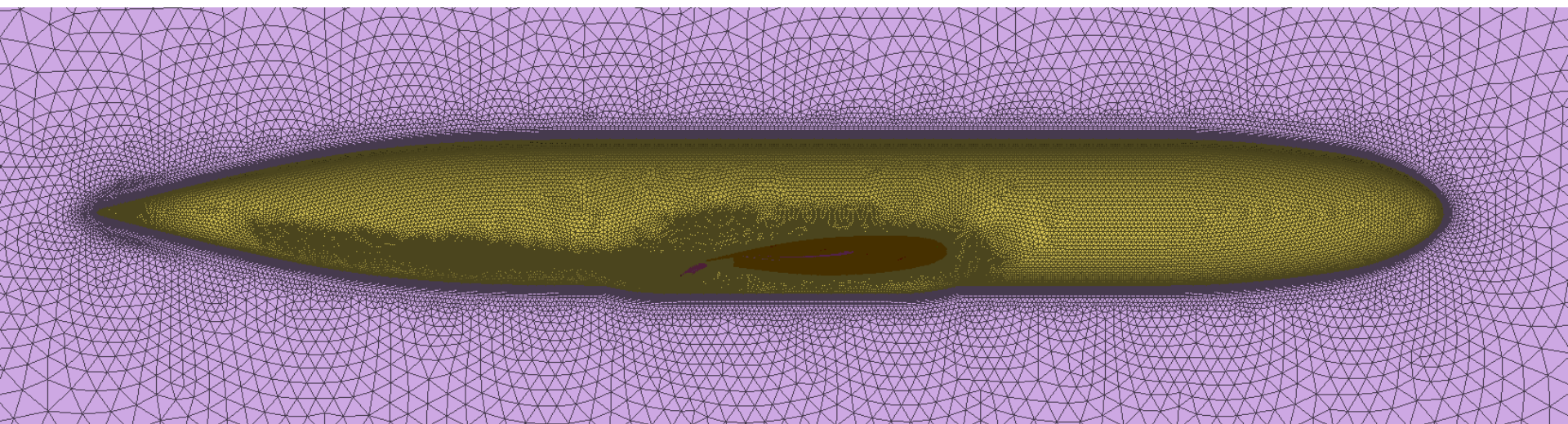

Middle Case 02 model

# Thank you

## Stay connected

website

[www.beta-cae.com](http://www.beta-cae.com)

support

[ansa@beta-cae.com](mailto:ansa@beta-cae.com)

social media

